

# CROSSOVER<sup>®</sup>

by Wascomat

**In a class by itself** – *The world's first small chassis washer engineered to commercial laundry standards for your business needs.*



## PROFESSIONAL SPECIFICATIONS

Serving the Multi-housing and Coin Laundry markets, Crossover Series Washers meet business demands with durability, energy savings and customer satisfaction.

## FEATURES AND BENEFITS

- ✓ Engineered to be superior to all competitors
- ✓ 15,000+ cycle machine life design
- ✓ Large high security coin vault
- ✓ Energy Star Rated
- ✓ 4 professional wash programs, + 2 cycle options
- ✓ Field adjustable water levels + cycle
- ✓ Top quality SKF bearings in heavy duty assembly
- ✓ 3 seals (with 5 lips) protect bearings
- ✓ AC motor (no brushes)
- ✓ Professional 8-point suspension
- ✓ Pump drain standard
- ✓ Solid steel counterweights—no concrete

## BEST CUSTOMER EXPERIENCE

- ✓ Extra big load wash basket—22+ pound capacity
- ✓ Superior oversuds and unbalance tolerance
- ✓ Extra large door opening
- ✓ Heavy-duty door hinge
- ✓ High speed 300G maximum extraction
- ✓ Simple, easy to use operation

## MARKET READY DESIGN

- ✓ Coin and card payment compatibility
- ✓ 3 compartment soap drawer
- ✓ 27" width for easy plug-in top-loader replacement
- ✓ Soft-mount technology for easy installation on any floor
- ✓ Meets ADA regulations

MODEL NOS:

Model No. WHWF09810M (coin)

Model No. WHWF09810DC (card)

NOTE: Money boxes are sold separately

# CROSSOVER

866.580.1010 ✓ [www.crossoverlaundry.com](http://www.crossoverlaundry.com)



# CROSSOVER WASHER

## CROSSOVER WASHER SPECIFICATIONS

<b>Model No.</b>	Metered/Coin WHWF09810M
<b>Model No.</b>	Card Ready WHWF09810DC
<b>Motor</b>	Variable-speed, reversible, thermoprotected, high-efficiency, controlled induction
<b>Electrical Rating</b>	120 V/60 Hz / 1-phase
<b>Breaker Requirements</b>	15A
<b>Cylinder Volume</b>	3 1/2 cu ft (98 liters)
<b>Cylinder Diameter</b>	21 5/8 in (550 mm)
<b>Cylinder Depth</b>	18 1/4 in (464 mm)
<b>Wash Capacity</b>	22 lbs (10 kg)
<b>Door Opening</b>	15 in (380 mm)
<b>Wash Speed</b>	45 RPM
<b>Maximum RPM*</b>	1,000 RPM
<b>Maximum G-force*</b>	300 G
<b>Inlet Hose</b>	2 3/8 in (hoses included)
<b>Water Pressure</b>	10-90 psi (70-600 kPa)
<b>Drain Hose</b>	1 in (25.4 mm)
<b>Crated Weight</b>	314 lbs (142.7 kg)
<b>Uncrated Weight</b>	299 lbs (136 kg)
<b>Overall Dimensions</b>	W D H: 27 x 33 3/4 x 39 3/4 in w/o meter box W D H: 27 x 33 3/4 x 43 1/2 in w/meter box (W D H: 686 x 857 x 1010 mm w/o meter box) (W D H: 686 x 857 x 1106 mm w/meter box)

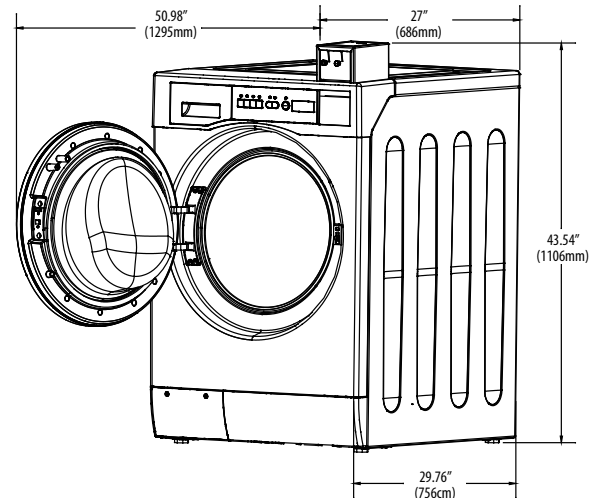

Refer installation and servicing to qualified, licensed personnel. Always read Installation and Operating Manuals and consult local codes before installation. Protect machines with properly rated circuit breakers ONLY. Warranty void if not properly installed. Specifications subject to change without notice. Laundrylux assumes no responsibility for errors or omissions in this information.

*Laundrylux offers a complete line of Electrolux Professional and Wascomat Commercial Laundry equipment.*

# CROSSOVER

866.580.1010 ✓ [www.crossoverlaundry.com](http://www.crossoverlaundry.com)

CROSSOVER • 461 Doughty Blvd., Inwood, NY 11096  
Sales and Administration Tel: 516-371-4400 • Fax: 516-371-4204 • [sales@laundrylux.com](mailto:sales@laundrylux.com)  
Spare Parts Tel: 516-371-2000 • Fax: 516-371-4029 • [parts@laundrylux.com](mailto:parts@laundrylux.com)  
Technical Support – Tel: 516-371-0700 • Fax: 516-371-4029 • [service@laundrylux.com](mailto:service@laundrylux.com)  
En Mexico: Llame gratis a este numero 001-800-010-1010